

## MYOCARDIUM/ENDOCARDIUM/PERICARDIUM

# Familial Dilated Cardiomyopathy in Patients Transplanted for Idiopathic Dilated Cardiomyopathy

Lorenzo Monserrat, Manuel Hermida, Beatriz Bouzas, Ignacio Mosquera, Niall Mahon<sup>a</sup>, Jesús Peteiro, Nemesio Álvarez, Manuel Penas-Lado, Marisa Crespo and Alfonso Castro-Beiras

Servicio de Cardiología. Hospital Juan Canalejo. A Coruña. <sup>a</sup>St. George's Hospital Medical School. London. United Kingdom

**Objective.** To evaluate the prevalence, clinical features, and pattern of inheritance of familial dilated cardiomyopathy (DCM) in heart transplant patients.

**Patients and method.** Patients with idiopathic DCM who had undergone heart transplantation were invited to participate. Patients with alcohol abuse were not excluded. A clinical evaluation, 12-lead ECG, echocardiogram, blood tests, and DNA extraction were performed in patients and relatives. Familial DCM was defined as the presence of at least one relative with idiopathic DCM. Possible familial DCM was considered when at least one relative had left ventricular enlargement (LVE) (> 112% predicted LVEDD).

**Results.** One hundred and ninety-nine relatives of 43 families were studied. DCM was familial in 11 probands (25.6%) and possibly familial in 11 (25.6%). Fifteen relatives had DCM (7.5%), 26 (13.1%) LVE, and 5 (2.5%) hypertrophic cardiomyopathy. The pattern of inheritance was autosomal dominant in most families. Five probands (3 with familial DCM) had antecedents of consanguinity and possible recessive inheritance. Six probands (14%, 1 with familial DCM) had relatives with conduction system defects. Creatine kinase was moderately increased in 9 relatives (4.5%), 3 of them with LVE. Fifteen patients had at least moderate alcohol intake. Three of them had familial DCM (relatives without alcohol abuse) and 6 had possible familial DCM.

**Conclusions.** The prevalence of familial DCM is high in patients who undergo heart transplant. Left ventricular enlargement, conduction system abnormalities, and elevated creatine kinase may be early markers of familial disease. Hypertrophic cardiomyopathy is present in some relatives of patients with idiopathic DCM. Familial DCM is present in patients with a previous diagnosis of alcoholic DCM.

**Key words:** *Cardiomyopathy. Genetics. Transplantation.*

Full English text available at: [www.revespcardiol.org](http://www.revespcardiol.org)

This study was financed by a grant from the Fundación Española del Corazón and the Sociedad Española de Cardiología for Basic and Clinical Research in Cardiology in 1998.

Correspondence: Dr. L. Monserrat Iglesias.  
Servicio de Cardiología. Hospital Juan Canalejo.  
As Xubias, 84. 15006 A Coruña. España.  
E-mail: [Lorenzo\\_Monserrat@canalejo.org](mailto:Lorenzo_Monserrat@canalejo.org)

Received 12 November 2001.  
Accepted for publication 5 March 2002.

## Miocardiopatía dilatada familiar en pacientes trasplantados por miocardiopatía dilatada idiopática

**Objetivo.** Estudiar la prevalencia de miocardiopatía dilatada (MCD) familiar en pacientes trasplantados, los patrones de herencia y características de la enfermedad en las familias identificadas.

**Pacientes y método.** Los pacientes trasplantados por MCD idiopática fueron invitados a participar en el estudio: evaluación clínica, electrocardiograma, ecocardiograma y análisis de sangre en pacientes y familiares. Se define como MCD familiar la presencia de al menos un familiar con MCD idiopática y posible MCD familiar cuando algún familiar tiene dilatación ventricular izquierda (diámetro telediastólico > 112% del previsto) con función sistólica normal.

**Resultados.** Participaron 199 familiares de 43 familias. Se diagnosticó MCD familiar en 11 familias (25,6%) y posible MCD familiar en 11 (25,6%). Quince familiares tenían MCD (7,5%), 26 (13,1%) dilatación ventricular izquierda, y cinco (2,5%) miocardiopatía hipertrófica. El patrón de herencia fue autosómico dominante en la mayor parte de las familias. En cinco existía consanguinidad y posible herencia autosómica recesiva. Seis casos tenían familiares con trastornos de conducción. Se registraron cifras de creatinina elevadas en 9 familiares (4,5%), tres con dilatación ventricular izquierda. Quince pacientes referían consumo de alcohol al menos moderado. Tres de ellos tenían MCD familiar y seis posible MCD familiar.

**Conclusiones.** a) La prevalencia de MCD familiar es alta en pacientes sometidos a trasplante; b) la dilatación ventricular izquierda, anomalías del sistema de conducción y elevaciones de la creatinina pueden ser marcadores precoces de enfermedad familiar; c) algunos pacientes con MCD idiopática tienen familiares con miocardiopatía hipertrófica, y d) puede haber MCD familiar en pacientes con MCD asociada a consumo de alcohol.

**Palabras clave:** *Miocardiopatía. Genética. Trasplante.*

## INTRODUCTION

Idiopathic dilated cardiomyopathy (DCM) is a disease of the cardiac muscle that is characterized by the presence of ventricular dilatation, systolic and diastolic dysfunction, symptoms of congestive heart failure,

## ABBREVIATIONS

DNA: deoxyribonucleic acid.  
LVE: left ventricular enlargement.  
DCM: dilated cardiomyopathy.  
HCM: hypertrophic cardiomyopathy.  
WHO: World Health Organization.  
HTX: heart transplant.

and premature death due to heart failure or arrhythmias.<sup>1</sup> It originates a high mortality and in Spain is the second most frequent reason for heart transplantation after ischemic heart disease.<sup>2,3</sup> In the last 5 years, several studies have demonstrated a familial association in DCM. According to these studies, as much as 30% of patients have a relative with DCM or left ventricular dilatation, which may be an early stage of the disease.<sup>4-10</sup>

The familial association of the disease can be due as much to the influence of genetic as environmental factors. The pattern of inheritance observed most frequently is autosomal dominant, although families with patterns of autosomal recessive or X-related transmission exist.<sup>6-12</sup> Ten different loci associated with DCM of familial presentation have been identified: 1p1-q21, 1q32, 2q14-22, 2q31, 2q35, 3p22-25, 6q23-24, 9q13-22, 10q21-23, 15q14.<sup>11-15</sup> Most of these loci (seven out of ten) have been described in association with DCM in a single family. In the last two years, various genes have been implicated in the development of DCM of familial presentation:<sup>12-20</sup>

- Isolated DCM: cardiac alpha actin, betamyosin heavy chain, troponin T, some mutations of dystrophin.
- DCM with disease of the conduction system: lamin A/C, desmin.
- DCM associated with skeletal myopathy: dystrophin and dystrophin-associated complex, emerin, lamin A/C.
- DCM due to mitochondrial DNA mutations (frequently associated with multiorgan conditions).

It is interesting to note that mutations in the genes of betamyosin heavy chain, troponin T, and cardiac actin have been described in familial DCM as well as hypertrophic cardiomyopathy (HCM).<sup>20,21</sup>

Patients with idiopathic DCM can present a highly variable clinical course. Some patients have an unfavorable evolution that soon makes heart transplantation necessary. Other patients have a more favorable evolution, with stabilization or even clinical improvement over time. To date, the familial prevalence of DCM has been studied in heterogeneous groups of patients. No data exist on the prevalence of familial DCM in patients undergoing heart transplantation or

on the prevalence of familial DCM in Spain. The primary aims of this study were to study the prevalence of familial DCM in patients undergoing heart transplantation in our center, to study patterns of inheritance and the characteristics of DCM in the families identified, and to create a DNA bank for the study of the genetic anomalies responsible for the disease.

## PATIENTS AND METHOD

### Patients and their first-degree relatives

All patients undergoing heart transplantation at the Hospital Juan Canalejo de A Coruña with a diagnosis of idiopathic DCM confirmed by examination of the explanted heart were invited to participate in the study. Exclusion criteria were the presence before transplantation of significant coronary disease of the epicardial arteries (more than 50% stenosis), severe cardiac valve disease or congenital cardiac malformations, serious systemic disease, severe hypertension, specific cardiomyopathy, or myocarditis. Patients with a history of heavy alcohol intake were not excluded.

### Clinical study

A retrospective review was made of the clinical records of 100 transplantation patients who met the inclusion criteria. A genealogical tree was prepared of each patient and their first-degree relatives were offered the opportunity for a clinical examination. The clinical records of family members who had died were reviewed whenever possible. In the case of index patients and living first-degree relatives, after obtaining informed consent, a prospective study was made that included a complete medical history, physical examination, 12-lead electrocardiogram, echocardiogram, and complete blood tests. Blood samples were obtained for samples and DNA conservation.

### Definition of familial DCM

In accordance with the recommendations of the working group on myocardial and pericardial disease of the European Society of Cardiology, «familial dilated cardiomyopathy» was defined as existing *a priori* when one or more first-degree relatives of a patient had dilated cardiomyopathy diagnosed in this study or recorded in their medical records.<sup>22</sup> «Possible familial dilated cardiomyopathy» was considered to exist when no first-degree relative met criteria for DCM but there were first-degree relatives with left ventricular enlargement (LVE) in the echocardiogram.<sup>22</sup> DCM was diagnosed in accordance with the criteria of the World Health Organization (WHO).<sup>1</sup> LVE was considered to exist when the end-diastolic diameter of the left ventricle exceeded by more than 12% that expected for the

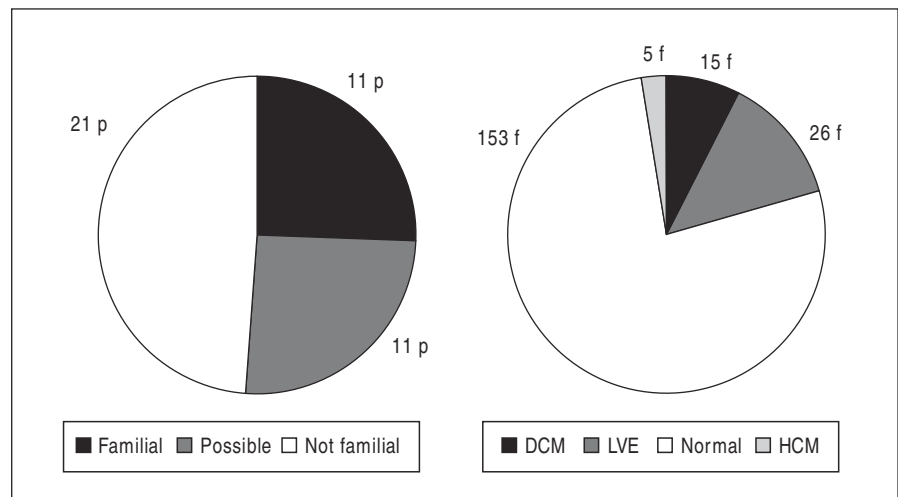

**Fig. 1.** Prevalence of dilated familial cardiomyopathy. The graph on the left shows the number of index cases with familial DCM, possible familial DCM, and no family disease. The graph on the right shows the number of first-degree relatives who are normal (n=153) or have LVE (n=26), DCM (n=15), and HCM (n=5).

**TABLE 1. Families with definitive or possible familial DCM**

Family	No. of first-degree relatives studied	No. of first-degree relatives with DCM relatives	No. of first-degree with LVE
1	22	2	2
10	4	1	1
16	5	2	1
21	14	4	1
25	6	1	0
38	3	1	0
43	7	2	1
45	9	1	2
52	3	1	0
59	3	1	0
60	13	2	0
4	4	0	2
12	6	0	3
13	3	0	2
23	11	0	2
27	5	0	1
35	4	0	3
37	1	0	1
41	4	0	2
42	4	0	1
47	2	0	1
55	2	0	1

groups were compared with the Student t test for independent samples in continuous variables. The  $\chi^2$  test was used for categorical variables. A value of  $P < .05$  (two-sided) was considered significant.

**RESULTS**

Forty-three families of patients who underwent transplantation for idiopathic dilated cardiomyopathy and a total of 199 first-degree relatives participated in the study.

**Prevalence of familial dilated cardiomyopathy**

Eleven index cases (25.6%) had a first-degree relative with DCM (familial DCM). Another 11 index cases (25.6%) had first-degree relatives with LVE and an EF of more than 50% (possible familial DCM). Therefore, 51.2% of the study subjects had a first-degree relative with DCM or LVE (Figure 1).

Table 1 summarizes the number of families studied and the number of first-degree relatives with DCM and with LVE in each family with familial DCM and possible familial DCM.

Figures 2-5 show the genealogical trees of some of the most representative cases of familial disease.

**Prevalence of DCM and LVE in first-degree relatives of patients undergoing heart transplantation for DCM**

Of the 199 first-degree relatives studied, 15 (7.5%) had DCM, 26 (13.1%) LVE with EF>50%, and 5 (2.5%) HCM. Therefore, 23.1% of the first-degree relatives studied had abnormalities suggestive of familial cardiomyopathy (Figure 1). In the 11 families with a diagnosis of familial DCM, a total of 100 first-degree relatives were studied (mean, 8.1±6 per family; median, 6; range, 3-22), of which 15 (15%) presented

individual's age and body surface area, and the ejection fraction (EF) was normal. The expected left ventricular diameter was calculated using the Henry formula (expected left ventricular end-diastolic diameter =45.3 [body surface area]<sup>1/3</sup>-0.03 [age]-7.2).<sup>23</sup>

**Analysis of results**

All data were analyzed using the SPSS statistical package for PCs. Patients with familial and non-familial DCM and the first-degree relatives of these two

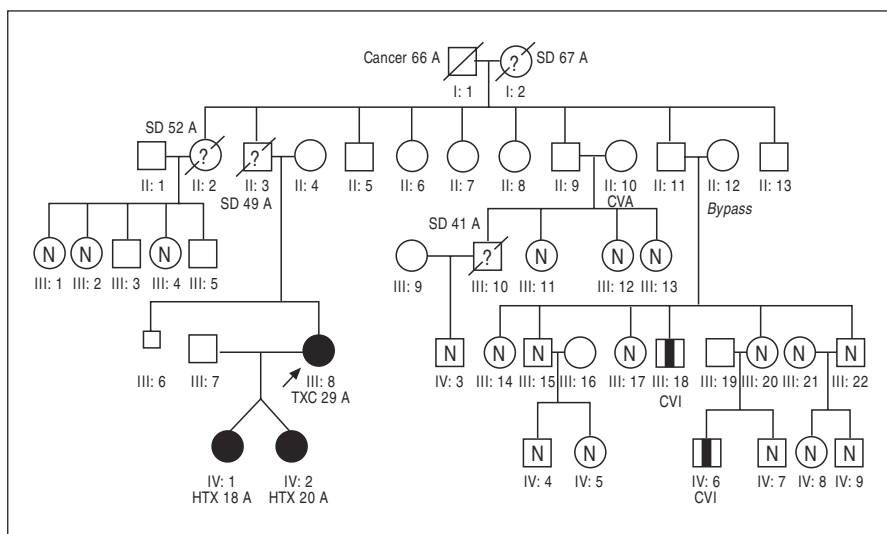

**Fig. 2.** Family 1. Three members of the family (mother: III: 8 and her twin daughters: IV: 1 and IV: 2) required heart transplantation (HTX) for DCM at age 37, 18 and 20 years, respectively. The electrocardiogram was low-voltage in all 3 patients. The mother had atrial fibrillation with a slow ventricular response. None of the three had evidence of skeletal myopathy or CPK elevation. The father of the mother (II-III) had died suddenly at the age of 52 years. The squares represent males and the circles represent females. The black symbols represent patients with DCM. The symbols with vertical black bars represent first-degree relatives with LVE. The diagonal lines indicate deaths. CVA indicates cerebrovascular accident; LVE, left ventricular enlargement; SD, sudden death, and N, not affected.

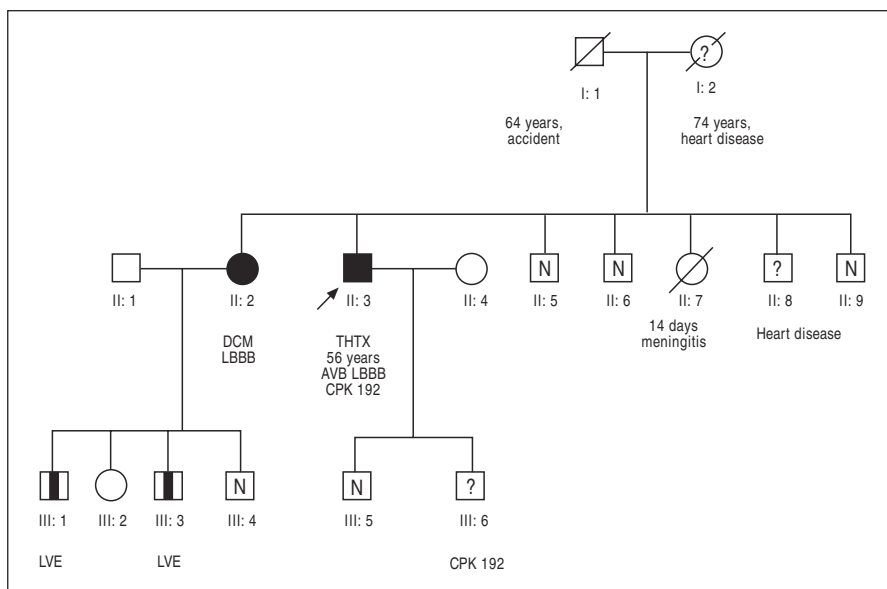

**Fig. 3.** Family 45. The index case is a male who was transplanted at age 56 years for idiopathic DCM (II: 3). At diagnosis he presented grade 1 AVB and left bundle-branch block with a CPK of 192 U/l (normal up to 195 U/l). A sister (II: 2) presented DCM and LBBB. Two of her offspring (III: 1 and III: 3) had LVE in the electrocardiogram. One son of the proband (III: 6) had a CPK of 349 with a normal echocardiogram. The family tree suggests an autosomal dominant pattern of inheritance, and the presence of conduction disorders and CPK elevation suggest the possible involvement of the lamin A/C gene. AVB indicates atrioventricular block; CPK: creatine phosphokinase; LVE: left ventricular enlargement; N: not affected; LBBB: left bundle-branch block; HTX: heart transplant.

DCM, 8 (8%) LVE, and 4 (4%) HCM, indicating that abnormalities were present in 27% of these first-degree relatives. Of the 15 first-degree relatives with DCM, 7 had died and the diagnosis of DCM was obtained from medical records.

### Patterns of inheritance detected in families with familial DCM

In the 11 families with familial DCM, the pattern of inheritance was autosomal dominant in 7 (64%) (Figures 2 and 3). In 3 of the 11 families (Figure 4), the existence of consanguinity suggests the possibility of an autosomal dominant or autosomal recessive inheritance. In the other family with DCM, the first-degree relatives affected were two siblings (*sib pair*).

A history of consanguinity was common in our pa-

tients and it was present in 3 families with familial DCM (Figure 4) 3 families without familial DCM (Figure 5), which represents 14% of the families studied.

### Clinical characteristics of transplanted patients

The mean age at time of diagnosis of DCM in study subjects was  $43.2 \pm 11$  years (median, 40 years; range, 19-61 years) and the mean age at time of transplantation was  $49.6 \pm 13$  years (median, 46 years; range, 19-67 years). From diagnosis to heart transplantation, the mean interval was  $5.6 \pm 4.5$  years (median, 5 years; range, 0-16 years). There was no significant difference in the age at diagnosis or the age at transplantation related with the presence or absence of familial disease.

None of the patients evaluated had a family history

of myopathy or muscular dystrophy. Three patients had a family history of type 2 diabetes mellitus. In 9 index cases there was a clinical suspicion of viriasis (without enzyme elevation) and/or possible myocarditis (with elevation of creatine phosphokinase in 3 patients) as a possible cause of the disease that was not confirmed by the endomyocardial biopsy made during the acute episode or in the later study of the explanted heart. In one patient with a previous condition suggestive of viriasis, familial DCM was detected, and in another 3, possible familial DCM. Six probands (14%) had a personal history of mild-to-moderate arterial hypertension (HTA). Two of these 6 had first-degree relatives with LVE. In the first electrocardiogram available for the probands, 15 of the 43 patients (35%) presented atrial fibrillation, 35 (83%), intraventricular conduction disorders (left bundle-branch block [LBBB] in 30), and 12 patients (28%), first-degree atrioventricular block. Five probands (12%) had a family history of conduction disorders that had required pacemaker implantation. In one other patient (Figure 5), atrioventricular conduction disorders were detected in the family study (isolated atrioventricular block in 2 siblings age 29 and 31 years, one with slightly elevated creatine phosphokinase levels –321 IU (normal laboratory values 10 to 195 IU). This last patient was referred to our hospital at age 19 years for an acute condition suggestive of severe refractory heart failure with CPK elevation (1066 IU/L) suggestive of myocarditis who required emergency heart transplantation. The pretransplantation endomyocardial biopsy and the study of the explanted heart did not reveal inflammatory infiltrates.

Creatine phosphokinase was measured in 79 of the 199 first-degree relatives studied. A value of more than 195 IU was recorded (higher than the reference values of our laboratory) in 9 of these first-degree relatives (11%) (and was above 250 in 6 of them). Three of these first-degree relatives, ages 19, 21, and 22 years, had left ventricular enlargement in the echocardiogram. Another 23 year old patient with LVE in the echocardiogram had a CPK of 191 IU. A sister of one of the first-degree relatives with high LVE and CPK cited had a CPK of 188 IU associated with first-degree atrioventricular block. The other 6 first-degree relatives with high CPK in the absence of LVE belonged to 6 different families: 2 with familial DCM (Figures 4 and 5), 2 with probable familial disease, and 2 with no other findings of familial DCM (one had first-degree atrial block) (Figure 5).

### Alcohol consumption and familial DCM

In 15 index cases (35%) of the 43 patients with DCM included in the study, a history of at least moderate alcohol consumption (over 50 g of ethanol per day) was found. Nine of them had consumed more

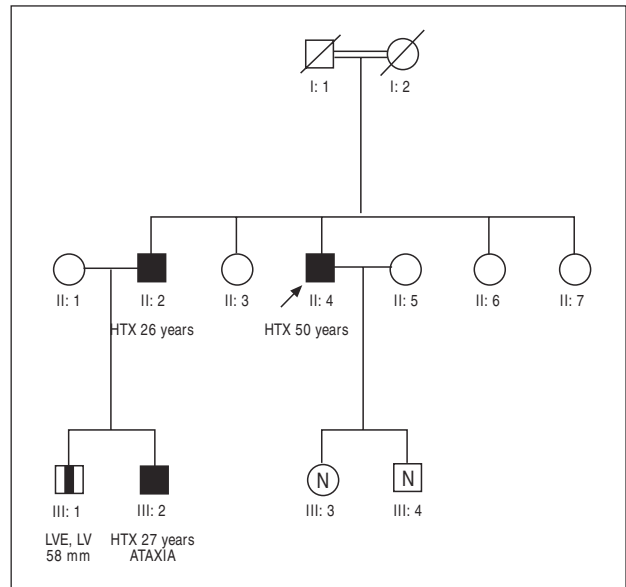

**Fig. 4.** Family 43. Two siblings (II: 2 and II: 4) developed idiopathic DCM and required heart transplantation (HTX) at age 67 and 60 years, respectively. Their parents were first cousins (I: 1 and I: 2). One son of patient II: 1 (III: 2) had been clinically diagnosed as Friedrich's ataxia in childhood. This patient did not develop hypertrophy, but did present DCM requiring HTX at age 27 years. The diagnosis of Friedrich's ataxia has not been confirmed genetically. No other relative has ataxia. His brother (III: 1) has LVE (left ventricular diastolic diameter, 58 mm; expected, 51 mm). The inheritance could be autosomal dominant or autosomal recessive (II: 1 would also have to carry the hypothetical genetic defect).

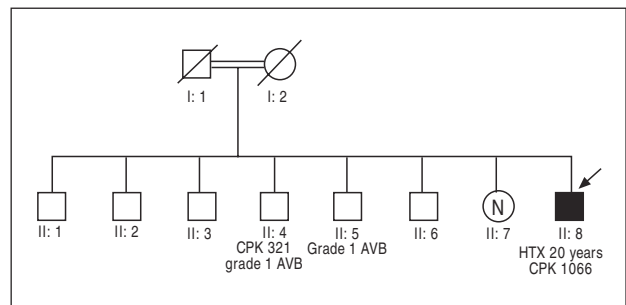

**Fig. 5.** Family 11. According to the criteria used in this study, this family did not have familial disease. The index case is a 19 year old male who presented severe acute refractory heart failure with CPK elevation (CPK 1066 U/L, normal up to 195) suggestive of myocarditis and required emergency heart transplantation (HTX). Neither the endomyocardial biopsy nor the explanted heart showed evidence of myocarditis that met the Dallas criteria. His parents, both alive and without heart disease, are first cousins. Of the 3 siblings that we have examined, 2 (II: 4 and II: 5) had first-degree atrioventricular block. Their CPK levels are 321 U/L and 143 U/L, respectively (normal up to 195). The inheritance could be autosomal recessive or X-linked.

than 80 g of ethanol a day for prolonged periods of time. Three patients with a previous diagnosis of DCM possibly secondary to alcohol consumption had familial DCM, with first-degree relatives who had

DCM unrelated to alcohol consumption. Two had a history of consanguinity. In another 6 patients with a history of alcohol consumption, first-degree relatives had LVE (possible familial DCM). In the other 6 patients with a history of alcohol consumption (moderate in 3 and severe in another 3), no familial disease was found.

## DISCUSSION

### Prevalence of familial DCM

The first studies on the prevalence of familial DCM, made by interrogating the patient about the family history of the disease, found very low rates of familial DCM.<sup>24-26</sup> Later, Michels et al,<sup>4</sup> in a systematic study of the first-degree relatives of 59 index cases, reported a prevalence of familial DCM of 20%. Other authors have reported similar results and the prevalence of familial disease is currently estimated to be 20% to 30%.<sup>5-11</sup> In any case, all the studies made have several limitations: they include only limited numbers of patients, they do not study all family members, and they use retrospective data (even in supposedly prospective studies). For example, in the study by Mestroni et al<sup>8</sup> of 350 consecutive patients with DCM, the family study was made in only 60 patients (17%) and familial disease was found in 39. In the study by Grünig et al,<sup>9</sup> the largest series in the literature, the family trees of 445 patients with idiopathic DCM were collected, but a family study was made in only 156 patients, in which the information obtained from the patients suggested that the disease could be familial. In this subgroup, familial disease was identified in 48 patients and possible familial disease (based on the presence of minor disorders in some family member) in 110 patients. Based on this information, the prevalence of confirmed familial disease (in a sample of 445 patients) was 10.8% and suspected familial disease, another 24%.<sup>9</sup> The same authors emphasize the diagnosis of 36 new cases of DCM found in their study of first-degree relatives. If a familial study had been made in the 289 patients in which it was not, it might have detected other cases of familial DCM. Gavazzi et al,<sup>10</sup> after excluding cases of X-linked DCM, studied 104 families, finding a family prevalence of disease of 24%. Baig et al<sup>7</sup> studied 225 first-degree relatives of 110 patients (a mean of only 2 first-degree relatives per patient) and reported a prevalence of possible familial disease (based on the presence of LVE or DCM in first-degree relatives) of 48%. As can be seen, the prevalence figures obtained vary and the total number of families included in the studies made in the last 10 years is about 500. Consequently, our study contains about 10% of the data published to date. These studies, in addition, are made in unselected populations of patients with DCM, of variable severity (generally

speaking, the main inclusion criterion was an EF of less than 40%-50%). In contrast, our study centered on patients who underwent heart transplantation, thus constituting an especially interesting group due to the seriousness of their disease and the possibility of confirming the diagnosis of idiopathic DCM in the study of the explanted heart. The prevalence of familial DCM in the patients who participated in the study was at least 26% (without taking into account the cases of «possible familial DCM»), but it could be much higher. In general, the first-degree relatives studied were young and a negative study does not exclude the possibility of genetic abnormalities that led to the disease.

Baig et al<sup>7</sup> confirmed that in a mean follow-up of 39 months, 27% of the first-degree relatives who presented LVE with a normal EF developed DCM. In our study, first-degree relatives with LVE were found in 25% of the index cases. Therefore, the prevalence of familial disease could be close to 50% of the study sample.

In order to estimate the true prevalence in transplanted patients, it is necessary to take into account that patients with suspected familial disease could be more predisposed to undergoing study, which would lead to overestimating the prevalence of familial disease. But even if none of the patients who did not participate had familial disease, the prevalence of familial DCM would be at least 11%, or 22% taking into account the presence of LVE as a criterion of possible familial disease. These limitations in the calculation of prevalence are common to most of the studies published.

On the other hand, the prevalence of disease of familial or genetic origin could be underestimated. In many cases there is a history of heart disease in the family that we could not consider positive in the absence of reliable registers. It is not possible to study all the first-degree relatives of each patient. In cases of X-linked cardiomyopathy, for example, the study of first-degree relatives could be negative, in spite of the presence of familial disease. It is especially difficult to detect cases of familial disease with an autosomal recessive inheritance. In our study a history of consanguinity was detected in 14% of the index cases. This high degree of consanguinity is related with the special demographic characteristics of our community, in which a high percentage of the population is found in small rural communities.

### Conduction system disease and familial DCM

Most of our patients presented intraventricular conduction disorders in the pretransplantation study, which is partly explained by the advanced-stage disease that they had. Twenty-eight percent of the index cases had first-degree atrioventricular block and 12% had a family history of conduction system disorders that required pacemaker implantation. The association

of conduction system disorders with later development of DCM of familial presentation has been described in relation with mutations in the genes of lamin A/C and ladesmin (in this case, cardiomyopathy often has a restrictive component).<sup>15,18,19</sup> Of the 6 probands who had first-degree relatives with conduction disorders, only one had familial DCM diagnosed according to criteria defined *a priori*. It is possible that in some of the other families the conduction disorder was a manifestation of familial disease.

### Viral infections, myocarditis, and familial DCM

In 9 index cases there was a clinical suspicion of virosis and/or possible myocarditis as a cause of the disease that later could not be confirmed. In 5 of them, there were findings suggestive of familial DCM. The limitations of the Dallas criteria in the diagnosis of myocarditis are known.<sup>27,28</sup> There are contradictory findings with regard to the importance of viral infections as a cause of DCM. In a study made in our transplanted patients, we did not detect signs of enterovirus infection in any of the 22 patients who underwent transplantation for idiopathic DCM.<sup>29</sup> In any case, it is possible that viral infections could have been the unidentified cause of DCM in some case. The virus (particularly enterovirus and adenovirus) can produce DCM by several mechanisms.<sup>28,30</sup> Acute myocarditis can produce serious myocardial damage with irreversible ventricular dysfunction. The organism's response to infection can lead to elimination of the virus followed by reduction of the inflammatory response (cure). If the immune response is insufficient, the virus can persist in the myocardium, producing a chronic myocarditis leading to DCM. Another possibility is that the immune response eliminates the virus but the later regulation fails to reduce the activity of cytotoxic lymphocytes, thus producing a chronic inflammation that also leads to DCM. All these phenomena (susceptibility, response capacity, and capacity for regulating the response to infection) depend on genetic factors. Therefore, there may be a familial association of DCM secondary to viral infections, which cannot be excluded in our patients.

### Hypertrophic cardiomyopathy in first-degree relatives of patients with DCM

Patients with HCM are identified in family studies of patients with DCM. In these cases, DCM could be the terminal phase of HCM, but there is evidence that both diseases may have a common genetic substrate. Mutations in the genes of cardiac actin, betamyosin heavy chain, and troponin T are associated with HCM and familial DCM.<sup>20,21</sup> Manifestation as hypertrophy, with or without later dilatation, or as primary DCM (without previous development of hypertrophy) could

depend not only on the region of the gene affected by the mutation and on the specific mutation, but also on the influence of multiple genetic and environmental factors.

### Alcohol consumption and familial DCM

Excessive alcohol consumption is a well known cause of potentially reversible DCM.<sup>31</sup> To our knowledge, this is the first study to demonstrate the presence of DCM in first-degree relatives of patients previously diagnosed as DCM secondary to alcohol consumption. This suggests that in these cases alcohol consumption, rather than a cause of the disease, is a trigger or coadjutant factor in its development. In general, in studies of the prevalence of familial DCM a history of important alcohol consumption is usually considered an exclusion criterion. However, DCM should be considered a multifactorial disease in which environmental and genetic factors act together. This consideration is especially important in populations like ours in which moderate to heavy alcohol consumption is common.

### Limitations of the study

The main limitation of this study was the low rate of participation of patients and their first-degree relatives in the family study, although we made it as easy as possible for them. This poor participation restricts the generalization of results to all transplanted patients. Many of the patients who did not participate in the study probably thought that it was not necessary since there was no evidence of familial disease. However, there were also patients in which the clinical history contained evidence suggestive of familial disease but the family did not participate in the study.

In any case, the finding of definitive DCM in 25% and probable DCM in another 25% of the transplanted patients who agreed to participate in the study is interesting, considering that the last two reports of the Spanish National Registry of Heart Transplantations indicated idiopathic DCM as the cause of 34% of heart transplants, and only a single case of familial DCM as the causal disease.<sup>2,3</sup>

### CONCLUSIONS

Familial DCM is frequent in patients undergoing heart transplantation with the diagnosis of idiopathic dilated cardiomyopathy. A complete family interview should be made in all patients and they should be offered the opportunity for a complete examination of first-degree relatives, since up to 25% of the first-degree relatives studied in this series had abnormalities suggestive of familial cardiomyopathy. The family study often discloses patients with dilatation of the left ventricle and normal EF, patients with conduction sys-

tem disorders, and cases of CPK elevation. These abnormalities could be the initial findings of cardiomyopathy, but their diagnostic value should be studied by prolonged clinical follow-up and identification of the genetic causes of the disease.

Patients with HCM are identified in the family study of patients with DCM. This is not strange considering that mutations in the same gene can produce both diseases. Alcohol consumption does not exclude the presence of familial DCM. Alcohol could be a trigger of cardiomyopathy in genetically predisposed subjects.

## REFERENCES

1. Report of the 1995 World Health Organization: «International Society and Federation of Cardiology Task Force on the definition and Classification of Cardiomyopathies». *Circulation* 1996;93:841-2.
2. Almenar L, en representación de los grupos españoles de trasplante cardíaco. Registro Español de Trasplante Cardíaco. XII Informe oficial. *Rev Esp Cardiol* 2001;54:1305-10.
3. Almenar L. Registro Español de Trasplante Cardíaco. XI Informe oficial. *Rev Esp Cardiol* 2000;53:1639-45.
4. Michels VV, Moll PP, Miller FA, Tajik AJ, Chu JS, Driscoll DJ, et al. The frequency of familial dilated cardiomyopathy in series of patients with idiopathic dilated cardiomyopathy. *N Engl J Med* 1992;326:77-82.
5. Goerss JB, Michels VV, Burnett J, Driscoll DJ, Miller FA, Rodeheffer R, et al. Frequency of familial dilated cardiomyopathy. *Eur Heart J* 1995;16:2-4.
6. Keeling PJ, Gang Y, Smith G, Seo H, Bent SE, Murday V, et al. Familial dilated cardiomyopathy in the United Kingdom. *Br Heart J* 1995;73:417-21.
7. Baig MK, Goldman JH, Caforio AL, Coonar AS, Keeling PJ, McKenna WJ. Familial dilated cardiomyopathy: cardiac abnormalities are common in asymptomatic relatives and may represent early disease. *J Am Coll Cardiol* 1998;31:195-201.
8. Mestroni L, Rocco C, Gregori D, Sinagra G, Di Lenarda A, Miovcic S, et al. Familial dilated cardiomyopathy: evidence for genetic and phenotypic heterogeneity. *J Am Coll Cardiol* 1999;34:181-90.
9. Grünig E, Tasman JA, Kücherer H, Franz W, Kübler W, Katus HA. Frequency and phenotypes of familial dilated cardiomyopathy. *J Am Coll Cardiol* 1998;31:186-94.
10. Gavazzi A, Repetto A, Scelsi L, Inserra C, Laudisa ML, Campana C, et al. Evidence-based diagnosis of familial non-X-linked dilated cardiomyopathy. *Eur Heart J* 2001;22:73-81.
11. Mestroni L, Milasin J, Vatta M, Pinamonti B, Sinagra B, Rocco C, et al. Genetic factors in dilated cardiomyopathy. *Arch Mal Coeur Vaiss* 1996;89:15-20.
12. Arbustini E, Morbini P, Pilotto A, Gavazzi A, Tavazzi L. Familial dilated cardiomyopathy: from clinical presentation to molecular genetics. *Eur Heart J* 2000;21:1825-32.
13. Arbustini E, Diegoli M, Morbini P, Dal Bello B, Banchieri N, Pilotto A, et al. Prevalence and characteristics of dystrophin defects in adult male patients with dilated cardiomyopathy. *J Am Coll Cardiol* 2000;35:1760-8.
14. Olson TM, Michels VV, Thibodeau SN, Tai YS, Keating MT. Actin mutations in dilated cardiomyopathy, a heritable form of heart failure. *Science* 1998;280:750-2.
15. Li D, Tapscoft T, Gonzalez O, Burch PE, Quinones MA, Zoghbi WA, et al. Desmin mutations responsible for idiopathic dilated cardiomyopathy. *Circulation* 1999;100:461-4.
16. Pathak SK, Kukreja PRC, Hess M. Molecular pathology of dilated cardiomyopathies. *Curr Probl Cardiol* 1996;21:99-144.
17. Tesson F, Sylvius N, Pilotto A, Dubosq-Bidot L, Peuchmaurd M, Bouchier C, et al. Epidemiology of desmin and cardiac actin gene mutations in a European population of dilated cardiomyopathy. *Eur Heart J* 2000;21:1872-6.
18. Fatkin D, MacRae C, Sasaki T, Wolff MR, Porcu M, Frenneaux M, et al. Missense mutations in the rod domain of lamin A/C gene as causes of dilated cardiomyopathy and conduction system disease. *N Engl J Med* 1999;341:1715-24.
19. Bonne G, Di Barletta MR, Varnous S, Bacane H, Hammouda E, Merlini L, et al. Mutations in the gene encoding lamin A/C cause autosomal dominant Emery-Dreifuss muscular dystrophy. *Nat Genet* 1999;21:285-8.
20. Kamisago M, Sharma SD, DePalma SR, Solomon S, Sharma P, McDonough B, et al. Mutations in sarcomere protein genes as a cause of dilated cardiomyopathies. *N Engl J Med* 2000;343:1688-96.
21. Mogensen J, Klausen IC, Pedersen AK, Egeblad H, Bross P, Kruse TA, et al. Alpha-cardiac actin is a novel disease gene in familial hypertrophic cardiomyopathy. *J Clin Invest* 1999;103:R39-R43.
22. Mestroni L, Maisch B, McKenna WJ, Schwartz K, Charron P, Roc Tesson F, et al. Guidelines for the study of familial dilated cardiomyopathies. Collaborative research group of the european human and capital mobility project on familial dilated cardiomyopathy. *Eur Heart J* 1999;20:93-102.
23. Henry WL, Gardin JM, Ware JH. Echocardiographic measurements in normal subjects from infancy to old age. *Circulation* 1980;62:1054-61.
24. Michels VV, Driscoll DJ, Miller FA. Familial aggregation of idiopathic dilated cardiomyopathy. *Am J Cardiol* 1985;55:1232-3.
25. Valentine HA, Hunt SA, Fowler MB, Billingham ME, Schroeder JS. Frequency of familial nature of dilated cardiomyopathy and usefulness of cardiac transplantation in this subset. *Am J Cardiol* 1989;63:959-63.
26. Mestroni L, Miani D, Di Lenarda A, Silvestri F, Bussani R, Filippi G, et al. Clinical and pathologic study of familial dilated cardiomyopathy. *Am J Cardiol* 1990;65:1449-53.
27. Mason JW, O'Connell JB, Herskowitz A, Rose NR, McManus BM, Billingham ME, et al. A clinical trial of immunosuppressive therapy for myocarditis. *N Engl J Med* 1995;333: 269-75.
28. Pauschinger M, Doerner A, Kuehl U, Schwimmbeck PL, Poller W, Kandolf R, et al. Enteroviral RNA replication in the myocardium of patients with left ventricular dysfunction and clinically suspected myocarditis. *Circulation* 1999;99:889-95.
29. Crespo-Leiro MG, Hermida-Prieto M, Pena F, Portela F, Muniz J, Hermida LF, et al. Absence of enteroviral RNA in hearts explanted from patients with dilated cardiomyopathy. *J Heart Lung Transplant* 2000;19:134-8.
30. Kawai C. From myocarditis to cardiomyopathy: mechanisms of inflammation and cell death. Learning from the past for the future. *Circulation* 1999;99:1091-100.
31. Urbano-Márquez A, Estruch R, Navarro-López F, Grau JM, Mont L, Rubin E. The effects of alcoholism on skeletal and cardiac muscle. *N Engl J Med* 1989;320:409-15.